



Request for Qualifications (RFQ)

#7-BTV-0224 Texas

TRANSPORTATION VEHICLE VENDORS

Closing Date:

2:00 PM CST

Monday, January 29, 2024

IDEA Public Schools (herein referred to as IDEA or the organization) is seeking Statement of Qualifications from qualified and experienced firms to place on an "Approved Vendor List," for current & future orders. Respondents should be able to provide primarily **Type A SPED, Type B SPED, Type C (seating capacity 71 + passenger) for Texas** according to the [Texas Department of Public Safety Specifications](#).

The qualified Respondent must be able to provide goods with the utmost diligence, cooperation, and ethical behavior in addition to being knowledgeable of industry standards as it relates to buses and other transportation vehicles for public schools. The chosen Respondent should also demonstrate high levels of trust, competence, and integrity.

IDEA reserves the right to revise and amend the qualifications before the date set for the receipt of the Statement of Qualifications. Respondents are requested to clarify any ambiguity, conflict, discrepancy, omission or other error(s) in the RFQ in writing. Revisions or amendments, if any, will be made by issuing an addendum. Every effort will be made to send an addenda issued to the parties known to have been furnished a complete copy of the RFQ. It is the responsibility of each respondent, before submitting the Statement of Qualifications, to contact IDEA to determine if an addenda was issued and, if so, to obtain such addenda for attachment to the Statement of Qualifications.

The first order is Identified in "Attachment I-First Order Price Sheet" and the Deadline for vehicle delivery is July 1, 2024.

Please contact solicitations@ideapublicschools.org to submit questions or comments concerning this solicitation, or to determine if addenda were issued and, if so, to obtain applicable addenda. The e-mail subject line should read **Questions - #7-BTV-0224 Texas**.

TABLE OF CONTENTS

PART I – GENERAL INFORMATION AND INSTRUCTIONS 3
First Quote Request..... 4
PART II – STATEMENT OF QUALIFICATIONS RESPONSE 8
PART III – REFERENCES 9
PART IV – REQUIREMENTS..... 9
PART V – EVALUATION 10
PART VI – REQUIRED ATTACHMENTS 10
Attachment A – Title Page 12
Attachment B – Respondent Certification 13
Attachment C – Certification Regarding Lobbying 14
Attachment D – Debarment or Suspension Certificate 15
Attachment E – Reference Sheet 16
Attachment F – Proof of Insurance or Bonding 18
Attachment G – Delivery Locations 19
Attachment H – First Order Vendor Questionnaire 20
Attachment I– First Order Price Sheet 21
Attachment J– Camera Specifications 24
Attachment K– General Price Sheet 25

THE REMAINDER OF THIS PAGE HAS BEEN INTENTIONALLY LEFT BLANK

PART I – GENERAL INFORMATION AND INSTRUCTIONS

General Information

IDEA Public Schools (“IDEA”) is a Texas nonprofit corporation and a tax-exempt organization pursuant to the Section 501(c)(3) of the Internal Revenue Code. Pursuant to Chapter 12, Subchapter D of the Texas Education Code and its Contract for Charter with the Texas State Board of Education, as renewed by the Commissioner of Education, IDEA is an open-enrollment charter holder, governmental entity and public school system. IDEA prepares Texas students from underserved communities for success in college and citizenship. IDEA is a growing network of 123 high-performing charter schools serving approximately 67,988 students located throughout Texas in the Austin, El Paso, Houston, Permian Basin, Rio Grande Valley, San Antonio, and Tarrant County regions. Although IDEA’s growth is rapid, it is also carefully planned. Schools begin with select grade levels and eventually reach full scale as a Pre-K-12 campus as grade levels are added to accommodate the students’ advancement.

IDEA’s mission is College for All. IDEA serves primarily low-income students in underserved areas of both rural and urban communities. Over 80% of IDEA students are considered low-income and one of every three students is the first in their family to go to college. Since the first graduating class in 2007, 100% of seniors have been accepted and matriculated to a college or university every year for fourteen consecutive years. Thanks to a rigorous path to college that begins in Pre-K, IDEA students attend selective universities throughout the country, win national awards and scholarships, and complete college at a rate six times the national average for low-income students.

Scope of Services

IDEA Public Schools is seeking a Statement of Qualifications from Respondents qualified and experienced in providing buses that meet [Texas Department of Public Safety Specifications](#) in quality and safety for public schools. Vehicles requested will be primarily **Type A SPED, Type B SPED, and Type C (seating capacity 71 + passengers)**.

Qualified Respondent(s) will be placed on a list of qualified vendors available for campus/departmental use. Respondents should be able to meet and uphold the following standards and qualifications as specified in this RFQ.

- a) Vendor shall ensure buses quoted and delivered meet the basic requirements as specified in this RFQ.
- b) Camera systems must come with each bus – **Attachment J** lists the basic requirements for buses to be quoted and delivered.
- c) **The factory name and location shall be submitted with the bid.** Any installation of equipment that is not to be performed at the vendor site/location shall be listed with location and vendor performing installation.

- d) The district intends to purchase the types of vehicles listed in this RFQ. When official order is made, the actual number purchased of any size bus may be adjusted up or down according to the district's needs and funding.
- e) All engines shall have the most current EPA Emissions Standards at the time of bid for the buses.
- f) Periodic inspections by IDEA staff may be made to ensure the buses are in accordance with Federal, State, and IDEA standards and good manufacturing principles. The district will incur the costs of the inspections and may bring in outside inspectors such as Certified Welding Inspectors and Mechanics. There shall be one inspection of each bus prior to full delivery of all buses. IDEA shall inspect these buses at the vendor location. This is to help ensure a faster delivery and fewer problems with buses meeting IDEA specifications.
- g) Vehicles quoted shall meet all FMVSS requirements and current state Texas for school buses as published.
- h) The vendor shall supply one spare rim for each bus purchased.
- i) **Floor diagrams must be included in the submittals.**
- j) IDEA Public Schools shall have the right to perform warranty repairs at their location and be reimbursed at full vendor's rate for approved equal parts and labor. **Proposer shall state their reimbursement labor rate per hour in their response.**
- k) General warranties are to include but will not be limited to:
 - a. Warranty shall be 3-Year/50,000 miles (starting form delivery date) of power train to include all internal engine parts, fuel system, computer software, hardware, programming, emissions controls/hardware and engine-driven accessories (excluding Air-Conditioning compressors), transmission, drive-line components, front & rear axle components (except consumable brake parts).
 - b. Starter and alternator shall have a 1-year warranty.
 - c. **Vehicle warranty information must be included in Request for Qualifications submission.**
- l) Vendor must submit a contingency plan if vehicles cannot be delivered by the requested date of the RFQ. An uncontrollable, unforeseen, out-of-normal operations event, such as an Act of God, would constitute a contingency plan.
- m) Respondents must also complete the **Vendor Questionnaire** in **Attachment H** of this RFQ.

First Quote Request

All vehicles must be received by July 1, 2024 (please provide pricing in "Attachment I")

IDEA is requesting the following buses for **Texas**:

- Quantity of 43 (forty-three) A/C equipped New or Semi-New Type "C" 71+ passenger school buses
- Quantity of 1 (one) A/C equipped New or Semi-New Type "B" 23+ passenger Special Education bus

- Quantity of 18 (eighteen) special education 10 seat vans OR Type “A” buses with 10 to 12 passenger seats
- Quantity of 10 (ten) 10-seat passenger vans for Mckinney Vento campus
- All buses under contract shall not be more than five (5) years old and shall not have more than fifty-five thousand (55,000) odometer miles upon arrival to their final destination in Weslaco, Texas or their respective region.
- The age of the vehicles will be determined as of August 1, 2023.
- Buses must be received by July 1, 2024.**
- New or semi-new buses will be considered for Texas.

Please note that vehicle warranty information, floor diagrams, total cost to include delivery (if applicable), factory name and location, and delivery date must be submitted with each qualification.

Statement of Qualifications Submission Requirements

Statement of Qualifications should be prepared in such a way as to demonstrate a straightforward, concise delineation of capabilities that satisfy the requirements of the RFQ. Emphasis should be concentrated on the vendor’s ability to meet the specifications and requirements in this RFQ.

To be considered, the Statement of Qualifications must be prepared according to the following specifications:

- a. Statement of Qualifications should include the following information and content.
 - I. Cover Letter
 - II. Table of Contents
 - III. Respondent(s)/Individual Profile
 - IV. Vehicle warranty information & floor diagrams
 - V. Price sheet & delivery timeframes (Attachments I & K)
 - VI. References
 - VII. Vendor Questionnaire
 - VIII. Required Forms
- b. Statement of Qualifications shall be submitted via mail to **IDEA Public Schools Headquarters, Attn: Purchasing Department, 2115 W Pike Blvd, Weslaco, TX 78596**, via [Tyler Munis Vendor Self-Service](#) portal, or via [Public Purchase](#).
- c. To be eligible for consideration Statement of Qualifications should be received electronically or by mail to the IDEA Public Schools Headquarters no later than **2:00 PM CST on January 29, 2024**, along with the requisite signature pages and completed certification forms.

All Statement of Qualifications must be received by the deadline. Statement of Qualifications submitted after the opening time and date will not be accepted. Faxed or emailed statements of Qualifications will not be accepted.

- d. **Statement of Qualifications Guarantee:** Statement of Qualifications shall be honored for 120 days after due date or until agreement is in place.
- e. All supplemental information required by the RFQ must be included with the Statement of Qualifications. Failure to provide complete and accurate information may disqualify the respondent from consideration.
- f. All costs incurred in the preparation and submission of the RFQ response shall be borne solely by the Respondent. Where Respondents may be required to perform a presentation, give demonstrations, and provide samples and/or technical literature, or participate in any interview process as related to this RFQ, all costs shall be borne by the Respondent.
- g. Any Statement of Qualifications submitted in response to this RFQ will be irrevocable upon the closing time and remain open for acceptance for 120 days from the closing date whether or not another RFQ has been accepted.
- h. Submission of a Statement of Qualifications shall be construed to mean that the Respondent agrees to carry out all conditions set forth in this document. Any proposed variation from the specifications, terms, and conditions shall be clearly identified. Please provide details of any noncompliance with stated conditions. If no changes are indicated, IDEA shall expect to receive the service(s) exactly as specified.
- i. IDEA reserves the right to select any offer it determines provides the best value, regardless of price.
- j. IDEA may accept multiple offers for the same services. There may not be exclusivity with any selected Respondent.
- k. **Request For Qualifications Tentative Timeline**

RFQ Issue Date:	January 8, 2024
Respondent Question Cut-Off Date:	January 15, 2024, at 2:00 PM (CST)
Addendum Issue Date:	January 23, 2024
Statement of Qualifications Due Date & Time:	January 29, 2024, at 2:00 PM (CST)
Evaluation Period:	February 1 – February 6, 2024
Board Meeting:	February 23, 2024

Required Forms (Certifications and Representations)

Respondent shall execute the stated required forms included with this Request for Qualifications.

RFQ Clarification

Questions regarding the requirements specified in this RFQ must be submitted via email to the **IDEA Public Schools Solicitations Division** at solicitations@ideapublicschools.org no later than **January 15, 2024, at 2:00 PM CST**. The email subject line should read: Questions- RFQ 7-BTV-0224 Texas. Questions submitted by Respondents by the submission deadline and answers prepared by IDEA, along with any errata or addenda to this RFQ, if applicable, will be posted on the IDEA website at: <https://ideapublicschools.org/our-story/finance-budget/pcs/bids-rfps/>, on [Public Purchase](#), and on the [Tyler Munis Self Service](#) (Texas Only) website. IDEA will not answer questions verbally and any informal oral answers provided by IDEA or its agents shall not be binding. No modification or amendment to this RFP shall be valid unless it is set forth in writing, via a signed addendum or amendment from IDEA.

Proposer Responsibility

IDEA expects Respondents to be thoroughly familiar with all requirements of this RFQ. Respondent's failure or omission to examine any relevant form, article, site, or document will not relieve Respondent from any obligation regarding this RFQ. By submitting a Statement of Qualifications, Respondent is presumed to concur with all terms, conditions, and specifications of this RFQ. Any exception must be clearly defined and referenced to the proper paragraph in this RFQ. Objections considered by IDEA as excessive or affecting vital terms may reduce or eliminate respondent's prospects for award.

Completeness

Statement of Qualifications will represent a true and correct statement and shall contain no cause for claim of omission or error. Request for withdrawal of a Statement of Qualifications is allowed based on proof of mechanical error; however, Respondent may be removed from approved Respondent list.

False/Misleading Statements

Statement of Qualifications which contain false or misleading statements, or which provide references which do not support an attribute or capability of the proposed system or service, may be rejected. If, in the opinion of IDEA, such information was intended to mislead IDEA in its evaluation of the Statement of Qualifications and the attribute, condition, or capability as a requirement of the RFQ, the Statement of Qualifications shall be rejected.

Statement of Qualifications Signatures

The Statement of Qualifications must be signed by an individual with proper authority to obligate the Respondent. The signature should indicate the title or position that the individual holds in the partner (if applicable).

Selection of Respondent (s)

IDEA may award this RFQ to multiple Respondents or to the Respondent IDEA determines, in its sole discretion, provides the best value to IDEA, based upon the evaluation of Statement of Qualifications. Thus, the result will be determined by the applicable criteria as listed under **Evaluation Criteria** referenced in this RFQ. Once the Statement of Qualifications is received the qualifications will be evaluated by IDEA and then if needed interviews will be conducted with selected respondents.

Administrative Procedure for Bidder Complaints

Members of the public having complaints regarding the IDEA's purchasing procedures or operations may present their complaints or concerns to IDEA by writing to the following address:

**IDEA Public Schools Headquarters
Attn: Director of Procurement
2115 West Pike Blvd
Weslaco, TX 78596
956-377-8000**

PART II – STATEMENT OF QUALIFICATIONS RESPONSE

Statement of Qualifications may be submitted using the [Tyler Munis Self-Service](#) website (TEXAS ONLY), [Public Purchase](#), or by sending a hard copy to:

IDEA Public Schools
Attn. Purchasing Department
2115 West Pike Blvd
Weslaco, TX 78596

Statement of Qualifications must be in a sealed envelope marked with the RFQ Number and Title (#7-BTV-0224 Texas) and include:

1. One (1) clearly identified hard copy ORIGINAL of the Statement of Qualifications response.
2. One (1) copies of the Statement of Qualifications on FLASH DRIVE, marked with the Respondent's name.

Note: Submissions via fax or email will not be accepted.

The respondent's Statement of Qualifications itself shall be organized as identified in **Part One (1), Statement of Qualifications Submission Requirements.**

PART III – REFERENCES

The Proposer shall submit a **minimum of three (3) verifiable references**. It is desired that if the Proposer has performed this type of service(s) previously, those references be listed. It is recommended that the Proposer provide references that are similar or as closely related to this unique agreement, if possible. Each reference provided shall include:

- Reference's Name
- Contact Person
- Address, City, State, and Zip
- Contact Person Phone Number
- Brief Project Scope and Time Frame

****Enter references in Attachment E***

PART IV – REQUIREMENTS

A. STATEMENT OF QUALIFICATIONS OPENING

Statement of Qualifications Opening is scheduled for **January 29, 2024, at 2:00 PM (CST)**. A formal "opening" will not be held. Trade secrets and confidential information contained in Statement of Qualifications shall not generally be open for public inspection, but IDEA's records are a matter of public record.

B. WHO IS ELIGIBLE TO RESPOND

Respondents who can meet the requirements for quality and other terms of this RFQ package, and who are not debarred and/or suspended from conducting business with IDEA, federal and state-funded agencies are invited to respond. A prospective respondent, by submitting a Statement of Qualifications, represents to IDEA that it meets the following requirements:

- Possess or is able to obtain adequate financial resources as required to perform under this RFQ
- Is able to comply with the required scope of the RFQ
- Have a satisfactory record of integrity to ethics
- Be otherwise qualified and eligible to receive an award
- Be in service standing with the applicable national or state associations

PART V – EVALUATION

IDEA will evaluate each Respondent’s Statement of Qualifications(s) in the areas listed in this solicitation. The committee evaluating the Statement of Qualifications submitted in response to this RFQ may conduct interviews in order to allow Respondents to clarify or elaborate on their Statement of Qualifications. Upon completion of interviews or discussions, Respondents may be requested to revise any or all portions of their Statement of Qualifications.

35 Points	Total Cost
25 Points	Vendor’s ability to deliver buses by the designated deadline specified within this RFQ
15 Point	Vendor’s ability to provide quality buses that meet the required specifications as outlined in this RFQ
15 Points	Vendor’s ability to provide excellent customer service including resolving issues with goods delivered and repairs
10 Points	Vendor’s reputation as verified with three (3) verifiable references
100 Points	Total Possible Score

PART VI – REQUIRED ATTACHMENTS

The attachments listed below are required and should be included with the Statement of Qualifications, along with any other forms included in this RFQ. All forms requiring signature must be signed as indicated.

1. **Attachment A** – Title Page
2. **Attachment B** – Respondent Certification
3. **Attachment C** – Certification Regarding Lobbying
4. **Attachment D** – Debarment or Suspension Certification
5. **Attachment E** – References
6. **Attachment F** – Proof of Insurance or Bonding

7. **Attachment G** – Delivery Locations & Specifications
8. **Attachment H** – First Order Vendor Questionnaire
9. **Attachment I** – First Order Price Sheet (needed by July 1, 2024)
10. **Attachment J** – Camera Specifications
11. **Attachment K** – General Price Sheet

Remainder of the Page Intentionally Left Blank

Attachment A – Title Page

A Statement of Qualifications Submitted in Response to:

IDEA Public Schools

Request for Statement of Qualifications

**#7-BTV-0224 Texas
Transportation Vehicle Vendors**

Submitted By:

(Full Legal Name of Respondent)

On:

(Date of Submission)

Attachment B – Respondent Certification

I, the undersigned, submit this Statement of Qualifications and have read the specifications, which are a part of this RFQ. My signature also certifies that I am authorized to submit this Statement of Qualifications, sign as a representative for Vendor, and carry out services solicited in this RFQ.

Signature of Authorized Agent: _____

Printed Name and Title of Agent: _____

Respondent Name: _____

Address: _____

Telephone Number: _____

Fax Number: _____

Contact Person: _____

Email Address (if applicable): _____

Web Site Address (if applicable): _____

Attachment C – Certification Regarding Lobbying

Submission of this certification is a prerequisite for making or entering into this transaction and is imposed by section 1352, Title 31, U.S. Code. This certification is a material representation of fact upon which reliance was placed when this transaction was made or entered into. Any person who fails to file the required certifications shall be subject to a civil penalty of not less than \$10,000 and not more than \$100,000 for each such failure.

The undersigned certifies, to the best of his or her knowledge and belief, that:

No Federal appropriated funds have been paid or will be paid by or on behalf of the undersigned, to any person for influencing or attempting to influence an officer or employee of any agency, a Member of Congress, or an officer or employee of Congress, an employee of a Member of Congress, or any Board Member, officer, or employee of IDEA in connection with the awarding of Federal contract, the making of a Federal grant, the making of a Federal Loan, the entering into a cooperative agreement, and the extension, continuation, renewal, amendment, or modification of a Federal contract, grant, loan, or cooperative agreement.

If any funds other than Federal appropriated funds have been paid or will be paid to any person for influencing or attempting to influence an officer or employee of any agency, a Member of Congress, an officer or employee of Congress, an employee of a Member of Congress, or any Board Member, officer, or employee of IDEA in connection with this Federal grant or cooperative agreement, the undersigned shall complete and submit Standard Form –LLL, “Disclosure Form to Report Lobbying”, in accordance with its instructions.

The undersigned shall require that the language of this certification be included in the awarded documents for all covered sub-awards exceeding \$100,000 in Federal funds at all appropriate tiers and that all subrecipients shall certify and disclose accordingly.

Respondent Name

Signature of Authorized Respondent

Date

Printed Name and Title of Authorized Representative

Attachment D – Debarment or Suspension Certificate

IDEA is prohibited from contracting with or making sub-awards under covered transaction to parties that are suspended or debarred or whose owners/members/principals and certain employees are suspended or debarred. Respondent must certify that it and its owners/members/principals are not suspended or debarred under federal law and rule.

By submitting signing contract and this certificate, Respondent certifies that no suspension or debarment is in place, which would otherwise preclude Respondent or its Owner/Members/Principals or employees from receiving a federally funded contract under applicable federal regulations and federal OMB Circulars.

Respondent Name

Signature of Authorized Representative

Date

Printed Name and Title of Authorized Representative

Attachment E – Reference Sheet

Please list a **minimum of three (3) references** of agencies (governments, chartered nonpublic schools, community schools or school districts) that have used your products. We would prefer some of the references to be new customers in the last year, and Ohio agencies are preferred:

COMPANY NAME OR CONTACT PERSON

STREET ADDRESS	CITY	STATE	ZIP
----------------	------	-------	-----

CONTACT PERSON	TELEPHONE NUMBER
----------------	------------------

PRODUCTS/SERVICES USED

DESCRIBE AND DOCUMENT YOUR INVOLVEMENT WITH OTHER COMMUNITIES IN SIMILAR TYPE OF WORK

COMPANY NAME OR CONTACT PERSON

STREET ADDRESS	CITY	STATE	ZIP
----------------	------	-------	-----

CONTACT PERSON	TELEPHONE NUMBER
----------------	------------------

PRODUCTS/SERVICES USED

DESCRIBE AND DOCUMENT YOUR INVOLVEMENT WITH OTHER COMMUNITIES IN SIMILAR TYPE OF WORK

COMPANY NAME OR CONTACT PERSON

STREET ADDRESS

CITY

STATE

ZIP

CONTACT PERSON

TELEPHONE NUMBER

PRODUCTS/SERVICES USED

DESCRIBE AND DOCUMENT YOUR INVOLVEMENT WITH OTHER COMMUNITIES IN SIMILAR TYPE OF WORK

Attachment F – Proof of Insurance or Bonding

Please provide proof of insurance with RFQ submission. IDEA requires the minimum insurance coverage & limits as stated below:

MINIMUM INSURANCE COVERAGE & LIMITS FOR VENDORS AND PROFESSIONAL SERVICE PROVIDERS			
Type of Contractor	Required Coverage	Required Coverage Limits	Other
Vendor General Insurance Requirements	Commercial General Liability	Each Occurrence: \$1,000,000 General Aggregate: \$2,000,000 Personal and Advertising Injury: \$500,000	Additional Insured Endorsement
	Automobile Liability Including: <input type="checkbox"/> Owned Vehicles <input type="checkbox"/> Non-Owned Vehicles <input type="checkbox"/> Hired Vehicles <i>(Required for vehicles driven on school property)</i>	Combined Single Limit: \$1,000,000	
	Workers' Compensation* Employers' Liability	Limit: State- Statutory Each Occurrence \$500,000	Waiver of Subrogation Endorsement

Attachment G – Delivery Locations

Attachment G lists the delivery location(s) and basic requirements for transportation vehicles.

The Austin HQ location applies to the first order identified in the scope of work and listed in the **First Order Price Sheet- Attachment I.**

PLEASE NOTE THAT IDEA WOULD LIKE TO LEAVE DELIVERY AS AN OPTION and will be considered based on pricing

Delivery Locations

Region	Campus	Address	Delivery Date
Texas	RGV Warehouse	308 S. Utah Ave., Ste. A Weslaco, TX 78596	July 1, 2024
Texas (First Order-10 vans only – McKinney Vento campus)	Austin HQ	5816 Wilcab Rd. Austin, TX 78721	July 1, 2024

Attachment H – First Order Vendor Questionnaire

All questions must be answered with the submission of qualifications.

1. Is your company part of a cooperative contract? If so, please advise on the name of the cooperative, contract number, and expiration date of contract.

2. For the first order, can your company meet the required delivery date of July 1, 2024? If not, please explain.

3. Has your company ever failed to meet a delivery deadline? If yes, please explain.

4. What are some possible reasons that may arise that may **prevent** your company from meeting the delivery deadline of July 1, 2024, for all vehicles specified in the first order for this RFQ? What is the contingency plan(s) if the delivery deadline of July 1, 2024, **cannot** be met?

5. For the first order, are the requested 18 (eighteen) 10-passenger vans readily available to be delivered by the delivery deadline of July 1, 2024? If not, please explain and provide an alternative.

Attachment I– First Order Price Sheet

All school buses operated in Texas must meet federal standards and Texas Department of Public Safety School Bus Specification Standards. School buses must comply with the standards that are in effect as of the date of manufacture. The most recent set of standards were adopted on July 30, 2018 and any newer updates can be located at <https://www.dps.texas.gov/section/highway-patrol/texas-specifications-school-buses>.

ALL BUSES MUST BE RECEIVED BY JULY 1, 2024.

➤ **Indicate “NO BID” for items you would not like to quote**

PLEASE NOTE THAT IDEA WOULD LIKE TO LEAVE DELIVERY AS AN OPTION and will be considered based on pricing

Bus Type	Description	QTY	Reviewed Specs	Lead Time	Unit Price (\$ USD – Each)	Total Cost
Type “C” 71+ Passenger School Buses		43	<input type="checkbox"/>			
<ul style="list-style-type: none"> • Camera systems must come with each bus - Specs are provided at the end of the document • All engines shall have the most current EPA Emissions Standards at the time of bid for the buses. • The vendor shall supply one spare rim for each bus purchased. • General warranties are to include but will not be limited to: • Warranty shall be 3-Year/50,000 miles (starting from delivery date) of power train to include all internal engine parts, fuel system, • computer software, hardware, programming, emissions controls/hardware, and engine-driven accessories (excluding Air- • Conditioning compressors), transmission, drive-line components, front & rear axle components (except consumable brake • parts). • The starter and alternator shall have a 1-year warranty. • Seat belt assemblies shall conform to FMVSS No. 209, Seat Belt Assemblies. • Deadline for vehicle delivery is July 1, 2024 						
Type “B” 23+ Passenger Special Education Buses		1	<input type="checkbox"/>			
<ul style="list-style-type: none"> • Camera systems must come with each bus - Specs are provided at the end of the document • Buses should have a 24+3 seating arrangement or closest accommodation. • All engines shall have the most current EPA Emissions Standards at the time of bid for the buses. • The vendor shall supply one spare rim for each bus purchased. • General warranties are to include but will not be limited to: • Warranty shall be 3-Year/50,000 miles (starting from delivery date) of power train to include all internal engine parts, fuel system, 						

- computer software, hardware, programming, emissions controls/hardware, and engine-driven accessories (excluding
- Air-Conditioning compressors), transmission, drive-line components, front & rear axle components (except consumable
- brake parts).
- Starter and alternator shall have a 1-year warranty.
- Seat belt assemblies shall conform to FMVSS No. 209, Seat Belt Assemblies.
- Deadline for vehicle delivery is July 1, 2024

10-seat passenger vans for Mckinney Vento campus	10	<input type="checkbox"/>			
Special Education Vans OR Type "A" buses with 10-12 passenger seats (please specify if you are quoting the vans OR the Type "A" buses)	18	<input type="checkbox"/>			

Special Education Van Specs:

Van Make

Any Make Vans are accepted as long as they are manufactured with no more than 10 seats per Texas compliance on student transportation. We are seeking anywhere from 7 to 10-seater vans.

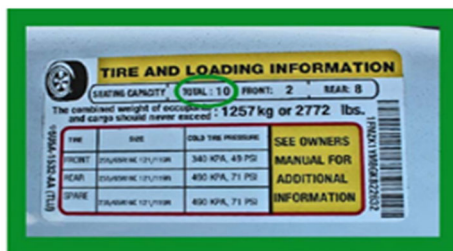

Engine

Any V6 or V8 options will be considered with a focus on the best power reliability and efficiency.

Interior

Fabric cloth seating will be preferred with everything else basic options that involve windows, trim and flooring. A rear cargo area can be provided as part of the layout.

Preferred seating layout will be including some examples below, **but all other layouts will still be considered:**

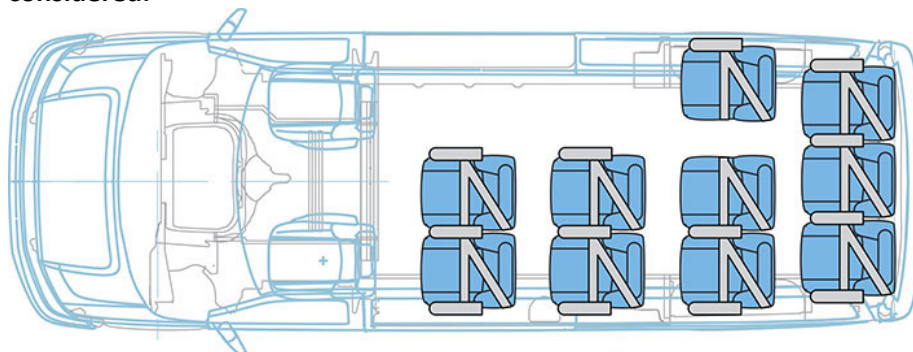

If ADA (only 4 of these units needed) other layouts will also be considered.

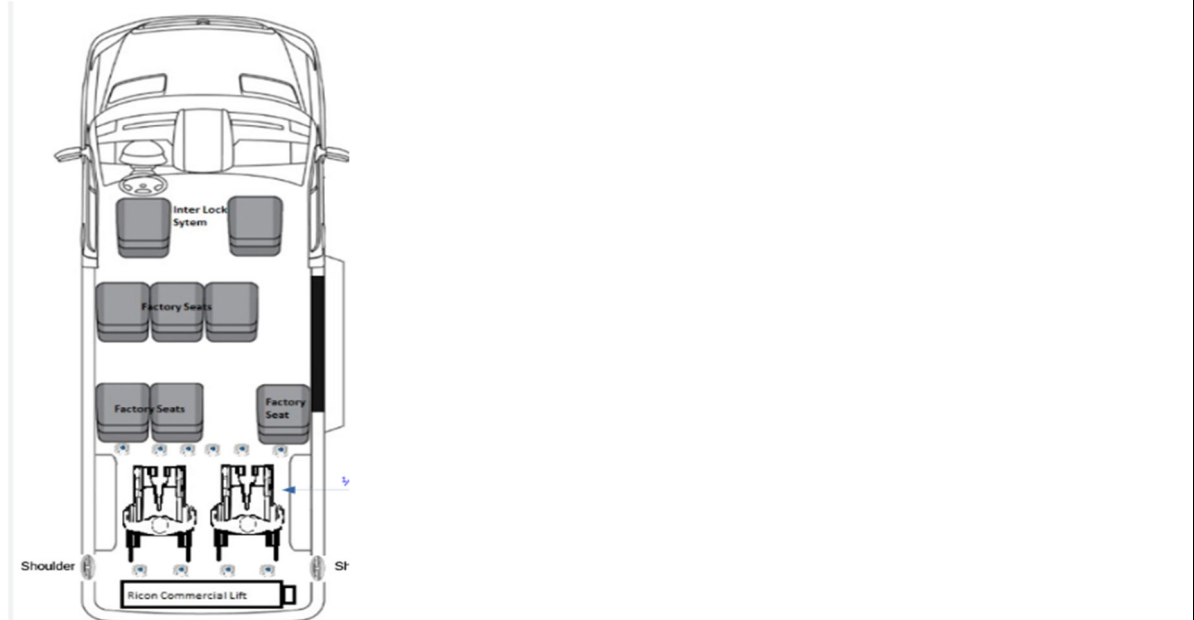

Exterior

Exterior van color is preferred at white but other can be considered.
 All doors must have child lock features for safety.

Tires

Tires can be highway rated or all season tires

Vehicle Package

Vehicle package, edition or trim level should be of the basic standard options, but others can be considered if pricing remains competitive.

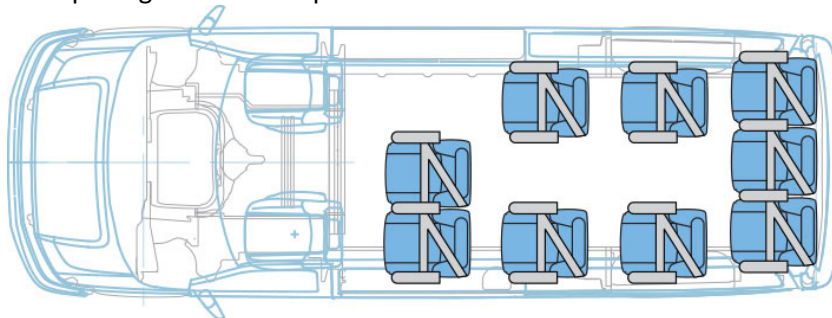

➤ **Indicate "NO BID" for items you would not like to quote**

TOTAL COST Delivery/Shipping	\$ _____
TOTAL COST	\$ _____
Warranty shall be included in the unit price of each Vehicle specified. Floor diagrams must be included in the submittals.	

Attachment J– Camera Specifications

Safety Vision-Cameras

6100 W. Sam Houston Pkwy. N.

Houston, TX 77041

Direct: 713-896-6600

Fax: 713-896-6640

4112HVR 4 Camera Complete
System 1TB Hard Drive

3 Year Warranty + 2 Year Extended Warranty Included

4112-HVR-1TBHDD 4112-HVR Kit With
Standard 1TB Hard Drive.41-GPS GPS Module
for 41 Series

41-PWRHRNS Power Harness 4000/4100/4108/4112/4116

41-TRIGGER Trigger Harness for 41 Series

4112-1TB-HDD 1 TB hard drive

4112-HVR 12 chan rec-8 analog 4 IP cam

SV-BATTERY-AAA Alkaline AAA Battery

Panic Button + Decals

41-PANIC-KIT Panic Button Kit for 41's

41-PANIC Panic Button for 4108/4112/4116

41-PANIC-CABLE Cable for 41-Panic. Use
with all but the 4000HYBSV-DECAL Audio & Video
Recording in Progress

Front WS Camera

AHD-H2.8M-BK 1080 AHD BLACK CAMERA W/OUT IR'S

SVS-5MMF 16ft 4in M/F THREADED CABLE

41-WS-BRKT front windshield bracket

Wide Angle Left of Driver Facing Doorway

AHD-WV AHD Wide View Camera

SVS-5MMF 16ft 4in M/F THREADED CABLE

Wide Angle Staggered Throughout Back of Bus

AHD-WV AHD Wide View Camera

SVS-10MMF 32ft 8in M/F THREADED CABLE

SVS-15MMF 49ft 4in M/F THREADED CABLE

Lifetime Software Updates, Maintenance, & Technical Support Charge INCLUDED

/4112/4120 Maintenance & Tech Support

WiFi Antenna

41-ANT-FEMALE wifi antenna for the 4100, 4108 & 4116

Attachment K– General Price Sheet

All school buses operated in Texas must meet federal standards and Texas Department of Public Safety School Bus Specification Standards. School buses must comply with the standards that are in effect as of the date of manufacture. The most recent set of standards were adopted on July 30, 2018 and any newer updates can be located at <https://www.dps.texas.gov/section/highway-patrol/texas-specifications-school-buses>.

PLEASE NOTE THAT IDEA WOULD LIKE TO LEAVE DELIVERY AS AN OPTION and will be considered based on pricing

Bus Type	Description	QTY	Reviewed Specs	Lead Time	Unit Price (\$ USD – Each)	Delivery /Shipping Cost
Type “C” 71+ Passenger School Buses		1	<input type="checkbox"/>			
<ul style="list-style-type: none"> • Camera systems must come with each bus - Specs are provided at the end of the document • All engines shall have the most current EPA Emissions Standards at the time of bid for the buses. • The vendor shall supply one spare rim for each bus purchased. • General warranties are to include but will not be limited to: • Warranty shall be 3-Year/50,000 miles (starting from delivery date) of power train to include all internal engine parts, fuel system, • computer software, hardware, programming, emissions controls/hardware, and engine-driven accessories (excluding Air- • Conditioning compressors), transmission, drive-line components, front & rear axle components (except consumable brake • parts). • The starter and alternator shall have a 1-year warranty. • Seat belt assemblies shall conform to FMVSS No. 209, Seat Belt Assemblies. 						
Bus Type	Description	QTY	Reviewed Specs	Lead Time	Unit Price (\$ USD – Each)	
Type “B” 23+ Passenger Special Education Buses		1	<input type="checkbox"/>			
<ul style="list-style-type: none"> • Camera systems must come with each bus - Specs are provided at the end of the document • Buses should have a 24+3 seating arrangement or closest accommodation. • All engines shall have the most current EPA Emissions Standards at the time of bid for the buses. • The vendor shall supply one spare rim for each bus purchased. • General warranties are to include but will not be limited to: • Warranty shall be 3-Year/50,000 miles (starting from delivery date) of power train to include all internal engine parts, fuel system, • computer software, hardware, programming, emissions controls/hardware, and engine-driven accessories (excluding • Air-Conditioning compressors), transmission, drive-line components, front & rear axle components (except consumable • brake parts). • Starter and alternator shall have a 1-year warranty. • Seat belt assemblies shall conform to FMVSS No. 209, Seat Belt Assemblies. 						

Bus Type	Description	QTY	Reviewed Specs	Lead Time	Unit Price (\$ USD – Each)
Special Education Vans OR Type “A” buses with 10-12 passenger seats (please specify if you are quoting the vans OR the Type “A” buses)	1	<input type="checkbox"/>			

Special Education Van Specs:

Van Make

Any Make Vans are accepted as long as they are manufactured with no more than 10 seats per Texas compliance on student transportation. We are seeking anywhere from 7 to 10-seater vans.

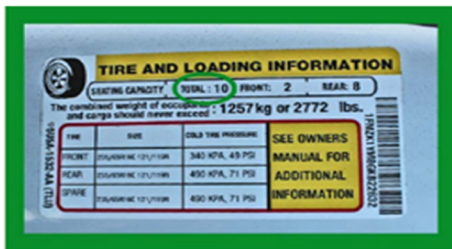

Engine

Any V6 or V8 options will be considered with a focus on the best power reliability and efficiency.

Interior

Fabric cloth seating will be preferred with everything else basic options that involve windows, trim and flooring. A rear cargo area can be provided as part of the layout.

Preferred seating layout will be including some examples below, **but all other layouts will still be considered:**

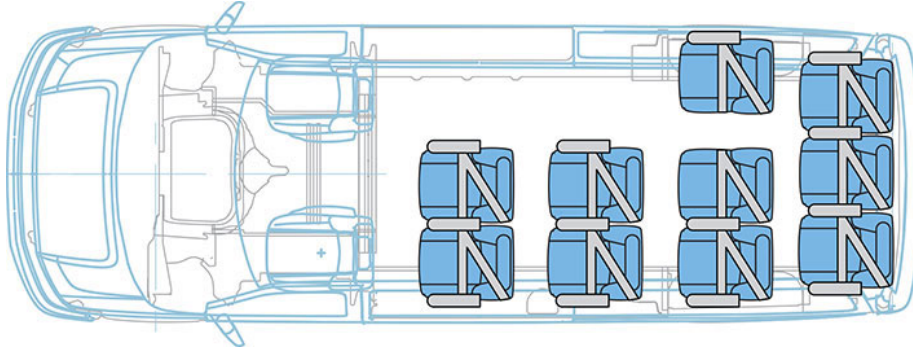

If ADA (only 4 of these units needed) other layouts will also be considered.

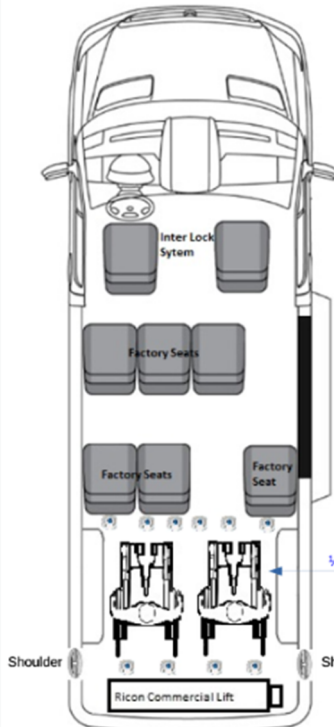

Exterior

Exterior van color is preferred at white but other can be considered.

All doors must have child lock features for safety.

Tires

Tires can be highway rated or all season tires

Vehicle Package

Vehicle package, edition or trim level should be of the basic standard options, but others can be considered if pricing remains competitive.

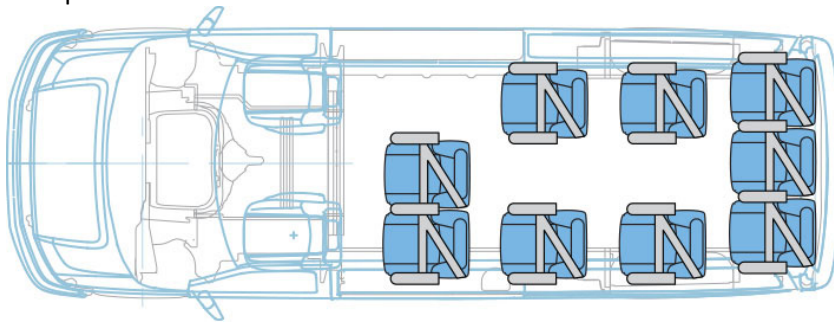

➤ **Indicate “NO BID” for items you would not like to quote.**

Warranty shall be included in the unit price of each Vehicle specified.

Floor diagrams must be included in the submittals.

END OF IDEA RFQ